

SELENIO



**MDX1
MPEG-2 Transport Stream
Multiplexer/Demultiplexer**

Installation and Operation Manual

SEL-MDX1

MPEG-2 Transport Stream Multiplexer/Demultiplexer

Installation and Operation Manual

Harris Corporation
Broadcast
Communications
Division
4393 Digital Way
Mason, OH USA
45040

Copyright © 2011, Harris Corporation, 1025 West NASA Boulevard, Melbourne, Florida 32919-0001 U.S.A. All rights reserved. This publication supersedes all previous releases. No part of this documentation may be reproduced in any form or by any means or used to make any derivative work without permission from Harris Corporation.

Harris Corporation reserves the right to revise this documentation and to make changes in content from time to time without obligation on the part of Harris Corporation to provide notification of such revision or change.

UNITED STATES GOVERNMENT LEGEND *If you are a United States government agency, then this documentation and the software described herein are provided to you subject to the following:*

All technical data and computer software are commercial in nature and developed solely at private expense. Software is delivered as "Commercial Computer Software" as defined in DFARS 252.227-7014 (June 1995) or as a "commercial item" as defined in FAR 2.101(a) and as such is provided with only such rights as are provided by Harris' standard commercial license for the Software. Technical data is provided with limited rights only as provided in DFAR 252.227-7015 (Nov 1995) or FAR 52.227-14 (June 1987), whichever is applicable. You agree not to remove or deface any portion of any legend provided on any licensed program or documentation contained in, or delivered to you in conjunction with, this User Guide.

This publication, or any part thereof, may not be reproduced in any form, by any method, for any purpose, without the written consent of Harris Corporation.

Contact Harris Corporation for permission to use materials as well as guidelines concerning foreign language translation and publication.

Harris Corporation reserves the right to revise and improve its products as it chooses. This publication is designed to assist in the use of the product, as it exists on the date of publication of this manual, and may not reflect the product at the current time or an unknown time in the future. This publication does not in any way warrant description accuracy or guarantee the use for the product to which it refers.

The Harris logo and assured communications are registered trademarks of Harris Corporation. D-Series is a trademark of Harris Corporation. All other trademarks are held by their respective owners.

This user guide was created for the Selenio SEL-MDX1, Edition A.

Windows is a registered trademark of Microsoft Corporation. AMD and Operton are trademarks of Advanced Micro Devices, Inc. Dolby and the double-D symbol are registered trademarks of Dolby Laboratories. Java is a trademark of Sun Microsystems, Inc. or its subsidiaries in the United States and other countries.

All other trademarks are the property of their respective holders.

Publication Date: March 2011

Contents

Preface	v
Manual Information	v
Purpose	v
Audience	v
Revision History	v
Writing Conventions	v
Obtaining Documents	vi
Unpacking/Shipping Information	vi
Unpacking a Product	vi
Product Servicing	vi
Returning a Product	vi
Safety Standards and Compliances	vii
Restriction on Hazardous Substances (RoHS) Compliance	vii
Waste from Electrical and Electronic Equipment (WEEE) Compliance	vii
Safety Terms and Symbols in this Manual	viii
Installation, Operation, and Specifications	1
Overview	1
Main Features	1
Front Module	3
Back Modules	4
Modules and Options	5
Signal Flow	6
Installing MDX1 Modules	7
Removing Selenio Modules	8
Front Module	8
Back Module	8
Powering Up a Module	9
Upgrading Module Firmware	9
Upgrade Failure Instructions	9
Parameter Descriptions	10
Module Name Block	10
Name	10
Function Map	10
Type	10
Demux PID Map	11
IP LANs	11
Primary and Secondary Data IP LANs	11
Time to Live	12
Primary and Secondary Data Eth MAC	12
Data Eth Protection	12

Selected Data Eth Interface	12
Multiplexers	13
Input Channels	14
DVBT Transmitter	16
General	16
.....	19
IP Destinations	19
DVB	19
DVBT	20
Output TS Status	20
Output IP Status	20
Carousel Status	20
Demultiplexers	21
General	21
IP Source	22
Input TS Status	22
Input IP Status	23
Output Channels	23
FEC	24
Demultiplexer PID Map	25
Conditional Access System	25
Vendor and CA Systems ID	25
ECMG	26
EMMG	26
Access Criteria	26
Conditional Access SCG 1-240	27
Multiplexer	27
Crypto Period	27
ECM	27
Reference Clock	28
Specifications	29
ASI Input and Output Specifications	29
SMPTE 310M Input and Output Specifications	30
Reference Clock	30
Index	31

Preface

Manual Information

Purpose This manual details the features, installation, operation, maintenance, and specifications for the Selenio SEL-MDX1 MPEG-2 Transport Stream Multiplexer/Demultiplexer.

Audience This manual is written for engineers, technicians, and operators responsible for installation, setup, maintenance, and/or operation of the Selenio SEL-MDX1 MPEG-2 Transport Stream Multiplexer/Demultiplexer.

Revision History **Table 2-1** Revision History of Manual

Edition	Date	Comments
A	March 2011	Initial release

Writing Conventions To enhance your understanding, the authors of this manual have adhered to the following text conventions:

Table 2-2 Writing Conventions

Term or Convention	Description
Bold	Indicates dialog boxes, property sheets, fields, buttons, check boxes, list boxes, combo boxes, menus, submenus, windows, lists, and selection names
<i>Italics</i>	Indicates E-mail addresses, the names of books or publications, and the first instances of new terms and specialized words that need emphasis
CAPS	Indicates a specific key on the keyboard, such as ENTER, TAB, CTRL, ALT, or DELETE
Code	Indicates variables or command-line entries, such as a DOS entry or something you type into a field
>	Indicates the direction of navigation through a hierarchy of menus and windows

Table 2-2 Writing Conventions

Term or Convention	Description
hyperlink	Indicates a jump to another location within the electronic document or elsewhere
Internet address	Indicates a jump to a website or URL
 NOTE:	Indicates important information that helps to avoid and troubleshoot problems

Obtaining Documents

Product support documents can be viewed or downloaded from our website. Alternatively, contact your Customer Service representative to request a document.

Unpacking/Shipping Information

Unpacking a Product

This product was carefully inspected, tested, and calibrated before shipment to ensure years of stable and trouble-free service.

- 1 Check equipment for any visible damage that may have occurred during transit.
- 2 Confirm that you have received all items listed on the packing list.
- 3 Contact your dealer if any item on the packing list is missing.
- 4 Contact the carrier if any item is damaged.
- 5 Remove all packaging material from the product and its associated components before you install the unit.

Keep at least one set of original packaging, in the event that you need to return a product for servicing.

Product Servicing

Except for firmware upgrades, SEL-MDX1 modules are not designed for field servicing. All hardware upgrades, modifications, or repairs require you to return the modules to the Customer Service center.

Returning a Product

In the unlikely event that your product fails to operate properly, please contact Customer Service to obtain a Return Authorization (RA) number, and then send the unit back for servicing.

Keep at least one set of original packaging in the event that a product needs to be returned for service. If the original package is not available, you can supply your own packaging as long as it meets the following criteria:

- The packaging must be able to withstand the product's weight.
- The product must be held rigid within the packaging.
- There must be at least 2 in. (5 cm) of space between the product and the container.
- The corners of the product must be protected.

Ship products back to us for servicing prepaid and, if possible, in the original packaging material. If the product is still within the warranty period, we will return the product prepaid after servicing.

Safety Standards and Compliances

The Selenio series safety manual is shipped in the *Harris Infrastructure and Networking Documentation and Product Resources DVD*, and can be downloaded from our website.

Restriction on Hazardous Substances (RoHS) Compliance

Directive 2002/95/EC—commonly known as the European Union (EU) Restriction on Hazardous Substances (RoHS)—sets limits on the use of certain substances found in electrical and electronic equipment. The intent of this legislation is to reduce the amount of hazardous chemicals that may leach out of landfill sites or otherwise contaminate the environment during end-of-life recycling. The Directive, which took effect on July 1, 2006, refers to the following hazardous substances:

- Lead (Pb)
- Mercury (Hg)
- Cadmium (Cd)
- Hexavalent Chromium (Cr-V1)
- Polybrominated Biphenyls (PBB)
- Polybrominated Diphenyl Ethers (PBDE)

According to this EU Directive, all products sold in the European Union will be fully RoHS-compliant and “lead-free.” (See our website for more information on dates and deadlines for compliance.) Spare parts supplied for the repair and upgrade of equipment sold before July 1, 2006 are exempt from the legislation. Equipment that complies with the EU directive will be marked with a RoHS-compliant emblem, as shown in [Figure 1](#).



Figure P-1 RoHS Compliance Emblem

Waste from Electrical and Electronic Equipment (WEEE) Compliance

The European Union (EU) Directive 2002/96/EC on Waste from Electrical and Electronic Equipment (WEEE) deals with the collection, treatment, recovery, and recycling of electrical and electronic waste products. The objective of the WEEE Directive is to assign the responsibility for the disposal of associated hazardous waste to either the producers or users of these products. As of August 13, 2005, the producers or users of these products were required to recycle electrical and electronic equipment at end of its useful life, and may not dispose of the equipment in landfills or by using other unapproved methods. (Some EU member states may have different deadlines.)

In accordance with this EU Directive, companies selling electric or electronic devices in the EU will affix labels indicating that such products must be properly recycled. (See our website for more information on dates and deadlines for compliance.) Contact your local Sales representative for information on returning these products for recycling. Equipment that complies with the EU directive will be marked with a WEEE-compliant emblem, as shown in [Figure 2](#).

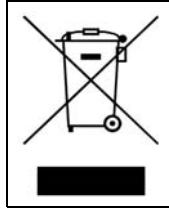

Figure P-2 WEEE Compliance Emblem

Safety Terms and Symbols in this Manual

This product manual uses the following safety terms and symbols to identify certain conditions or practices. See the *Selenio Safety Instructions and Standards Manual* for more information.



WARNING

Statements identifying conditions or practices that may result in personal injury or loss of life. High voltage is present.



CAUTION

Statements identifying conditions or practices that can result in damage to the equipment or other property.

Installation, Operation, and Specifications

Overview

The Selenio MDX1 multiplexer and demultiplexer encapsulates streams for transport, or it can multiplex, de-multiplex, and re-multiplex transport streams. Incoming programs can be readily re-purposed into new programs, local content added to existing programs, and new transport streams can be generated quickly.

The Selenio frame provides internal connectivity in which content can be routed from a variety of sources, including MPEG-2 and H.264 encoder modules, various internal network interfaces such as DVB-ASI, and from incoming Gigabit Ethernet transport streams.

External connections can include up to eight software-selectable independent inputs or outputs that can handle either DVB-ASI or the SMPTE 310M protocols.

The MDX1 is capable of accepting un-encrypted programs from a variety of sources from local encoders to network interfaces, including ASI or Gigabit Ethernet. It includes a Simulcrypt synchronizer to access conditional access information from a CA system over a dedicated Ethernet connection. Each program is encrypted using DVB common scrambling, and ECMs are multiplexed into each stream to provide a DVB-compliant output.

The encryption engine supports 256 simultaneous programs at a combined rate of up to 214 Mb/s. When not using encryption, the multiplexer supports up to an 800 Mb/s throughput.

Main Features

- Two back module configurations:
 - HD-BNC
 - Eight ASI/SMPTE 310M inputs/outputs on HD-BNC
 - 10 MHz reference input on HD-BNC
 - GPS 1 pps sync input on HD-BNC
 - HD-BNC and RJ-45
 - Five ASI/SMPTE 310M inputs/outputs on HD-BNC
 - 10 MHz reference on HD-BNC
 - GPS 1 pps sync input on HD-BNC
 - 10/100Base-T on RJ-45 for Simulcrypt server

- Transport stream input/output
 - Configurable as input or output per port
 - Configurable DVB-ASI or SMPTE 310M output per port
 - MPEG format 188/204 bytes per TS packet (188-byte internal only)
 - Data rate set from 2 pps internal time base, frame or GPS reference
 - Total module bandwidth of 800 Mb/s
 - Support for 256 programs and 4096 PIDs
 - PID or program multicasting up to eight destinations
- Multiplexing
 - Capability of up to eight individual multiplexes
 - Program multiplexing
 - Mirroring capability for any odd output port to adjacent even output port
 - PID insertion
 - Un-referenced PID insertion
 - High/low service prioritization
 - Automatic or manual PID/program numbering
 - Mux Bypass (passthrough)
 - Data Carousel
 - Local statistical multiplex of encoders
 - ACBR (Adaptive CBR), CBR, and capped VBR output modes
 - IP-to-IP multiplexing
- Conditional access
 - BISS or DVB Simulcrypt
 - Up to 256 control words
 - Max data rate of 200 Mb/s
- De-multiplexing
 - Capability of up to eight individual receive multiplexes
 - Program de-multiplexing
 - PID extraction
 - De-mux bypass (passthrough)
- Gigabit Ethernet
 - Access via frame data network
 - Support for 256/256 in and 240/240 out SPTS streams
 - Support for unicast and multicast reception/transmission
 - Source-specific joins, supported with multiple sources (IGMPv3)
 - FEC and encapsulation as per SMPTE 2022
 - Network jitter buffer and PCR recovery
- SFN adaptation
 - DVB SFN adaptor functions
 - DVB MIP insertion
 - 10 MHz and 1 pps timing input.
- SI/PSI processing
 - Support for combination PAT, PMT and SDT tables

- ❑ Inclusion of static tables via data carousel
- ❑ Inclusion of streaming tables as TS input stream
- ❑ Support for third-party PSI generation system integration
- ❑ Concurrent static and dynamic tables

Front Module

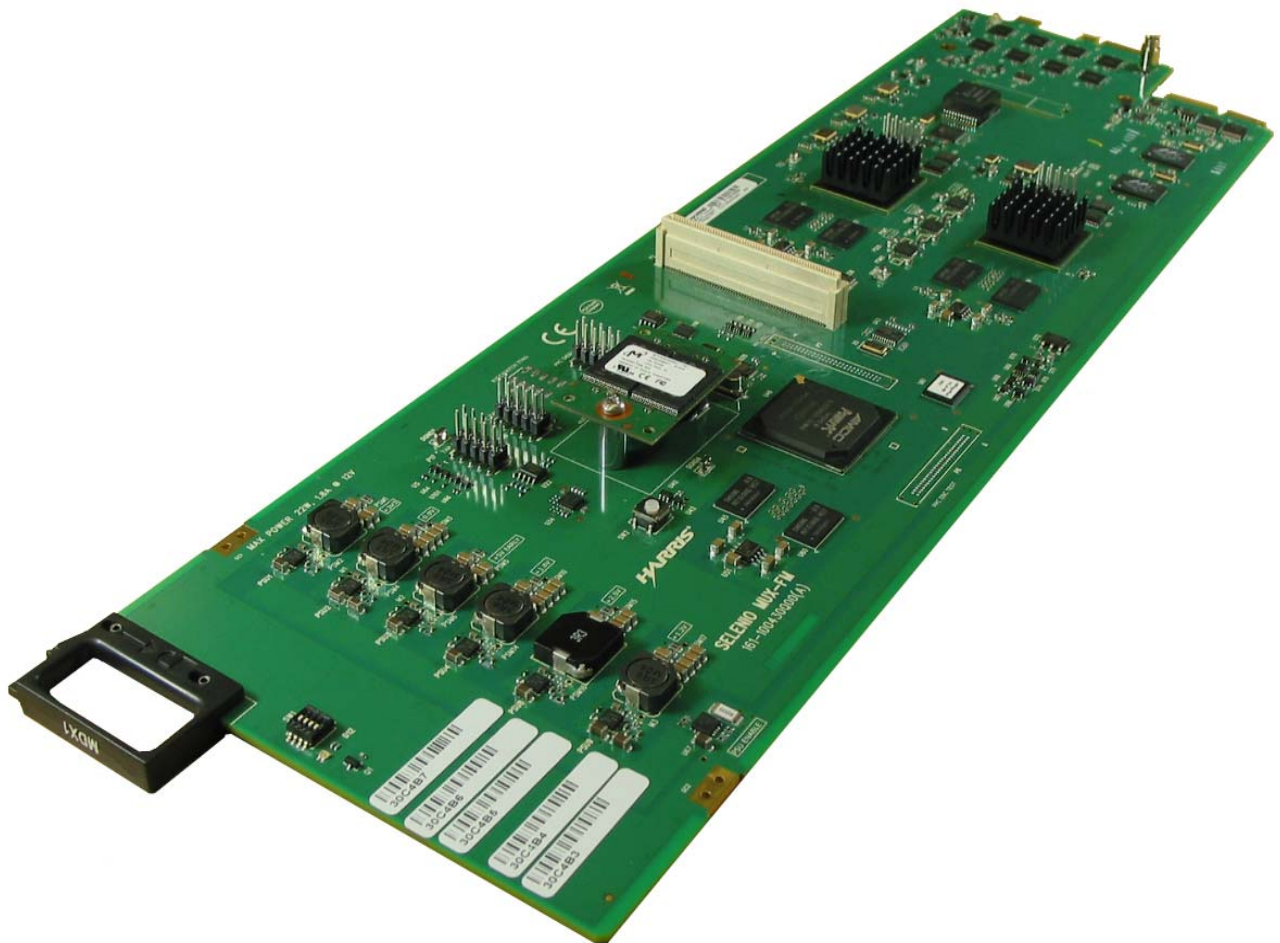

Figure 1-1 SEL-MDX1 Front Module

Back Modules

Selenio back modules are color-coded to help you identify different connectors more quickly.

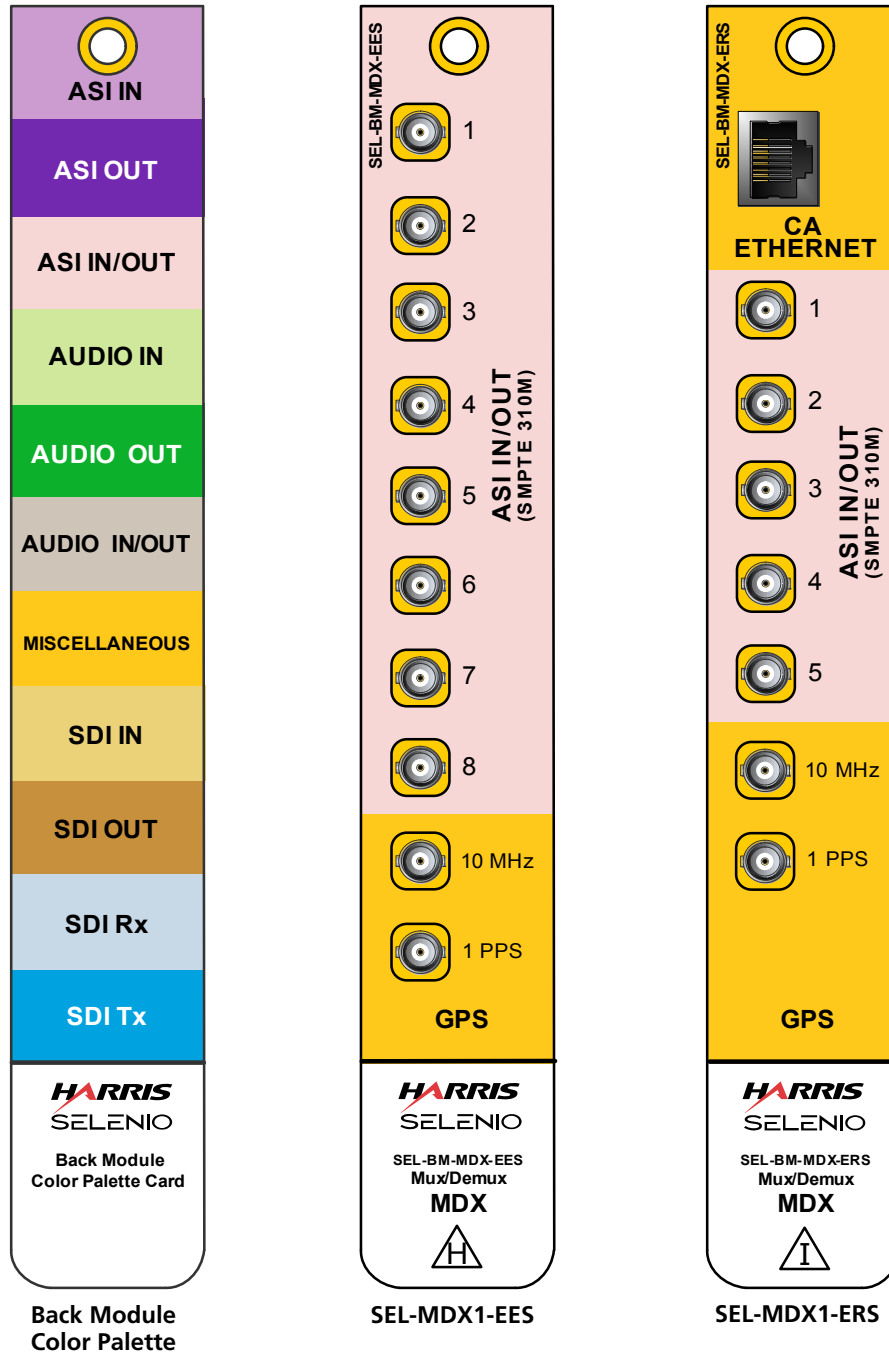

Figure 1-2 Selenio Mux Back Modules

Modules and Options



Note: Data Ethernet and internal module-to-module data Ethernet connectivity require the installation of a SELOPT-VIDEO-IP Video IP submodule on the Selenio frame controller module.

Table 1-1 Module Descriptions

Product	Description
SEL-MDX1-EES	MPEG-2 Transport Stream Multiplexer/Demultiplexer with 2 input or outputs dependent on software feature key, can be configured for SMPTE-310 or DVB-ASI, includes single back module with HD-BNC connectors (8 ASI ports) and 10 MHz and 1 PPS inputs. Must select software model key to enable functions
SEL-MDX1-ERS	MPEG-2 Transport Stream Multiplexer/Demultiplexer with 2 in/out dependent on software feature key, configurable for SMPTE-310 or DVB-ASI. Includes single back module with RJ-45 data (video IP) port and HD-BNC connectors (5 ASI ports), 10 MHz and 1 PPS inputs. Must select software model key to enable functions

Table 1-2 Module Types

Product	Description
SEL-SK-MX-ATSC	Software model key for MDX1 - ATSC transport stream multiplexer/de-multiplexer configuration
SEL-SK-MX-DVB	Software model key for MDX1 - DVB transport stream multiplexer/de-multiplexer configuration
SEL-SK-MX-ENCAP	Software model key for MDX1 - tunnel encapsulation (no multiplexing) configuration
SEL-SK-MX-ISDB	Software model key for MDX1 - ISDB transport stream multiplexer/de-multiplexer configuration
SEL-SK-MX-MPEG	Software model key for MDX1 - basic transport stream multiplexer/demultiplexer configuration

Table 1-3 Softkey Options

Product	Description
SELOPT-SK-MX-4CH	Software keyed option to select 4 in/out channels (adds 2 channels)
SELOPT-SK-MX-8CH	Software keyed option to select 8 in/out channels (adds 6 channels)
SELOPT-SK-MX-BISS	Software keyed option for BISS encryption
SELOPT-SK-MX-SCR	Software keyed option for BISS and Simulcrypt single channel encryption

Signal Flow

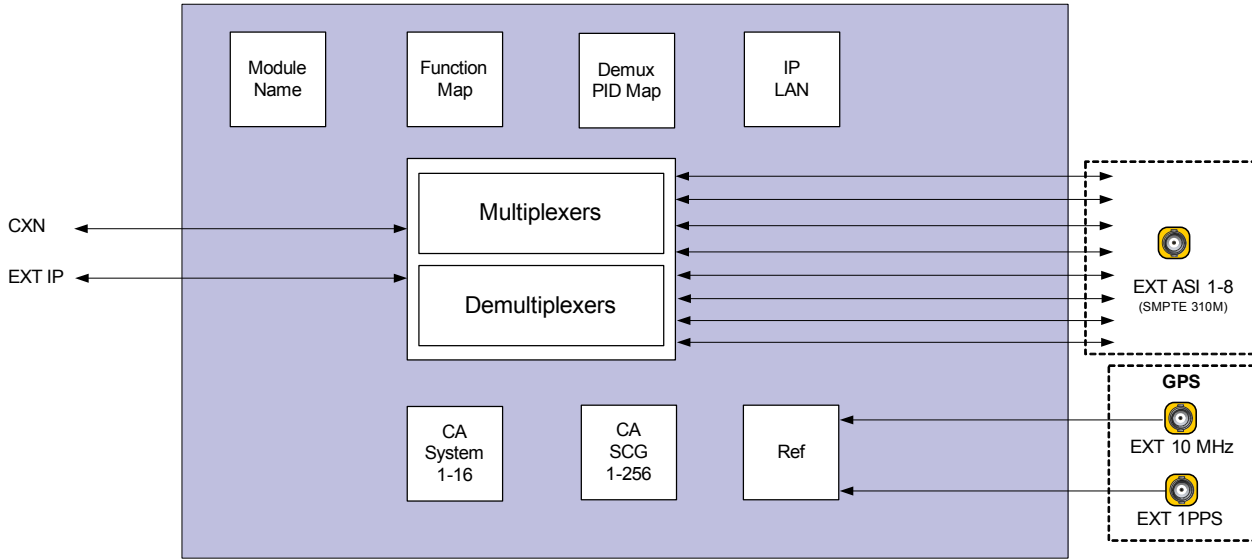

Figure 1-3 SEL-MDX1-EES Block Diagram

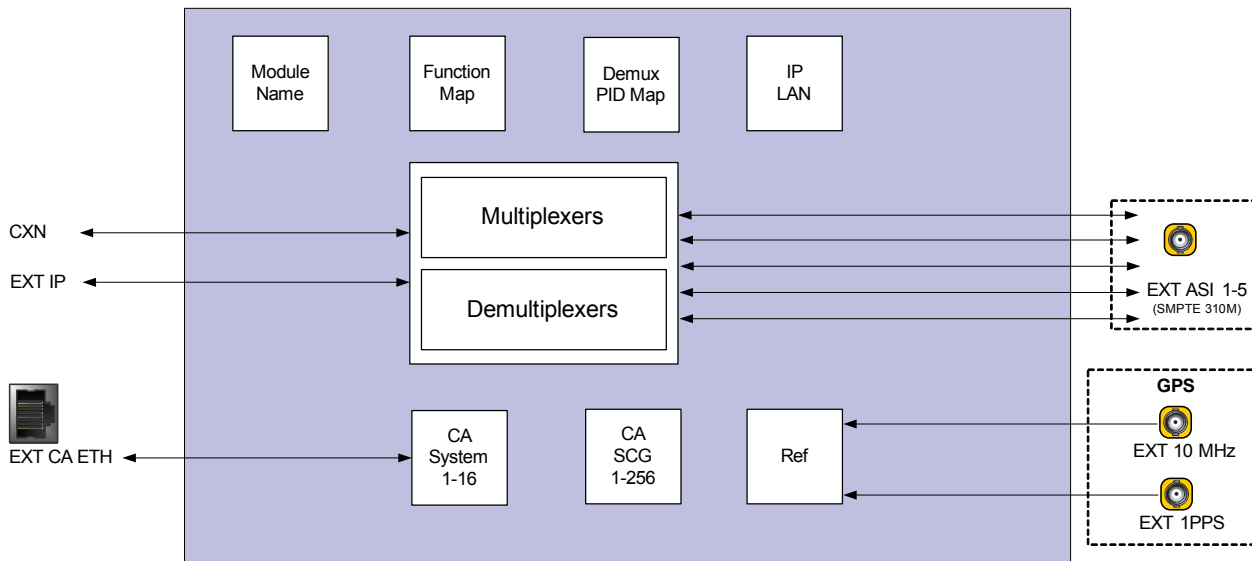

Figure 1-4 SEL-MDX1-ERS Block Diagram

Installing MDX1 Modules

Note: Selenio frames are designed for demanding broadcast networking applications in which a maximum of four MDX1 modules are required. To ensure optimum performance, do not install more than four MDX1 modules in each frame.

You can insert a Selenio module into a frame with the power supply turned on or off. Follow this procedure:

- 1 Remove a blank back module from the frame.
Save the blank back modules and their captive screws for future configurations.
- 2 Attach the new back module to the empty slot, using the mounting screws provided.
Ensure that the EMI gaskets separating the back modules remain in place during the installation. The EMI gaskets fit tightly. To ease the installation of back modules, gradually press each back module into place from the left side to the right side.
- 3 Apply labels to the back module, if these are supplied separately.
- 4 Print out this page and write down the placement of the back modules in the diagram below (back modules appear on the reverse side when viewed from the front).

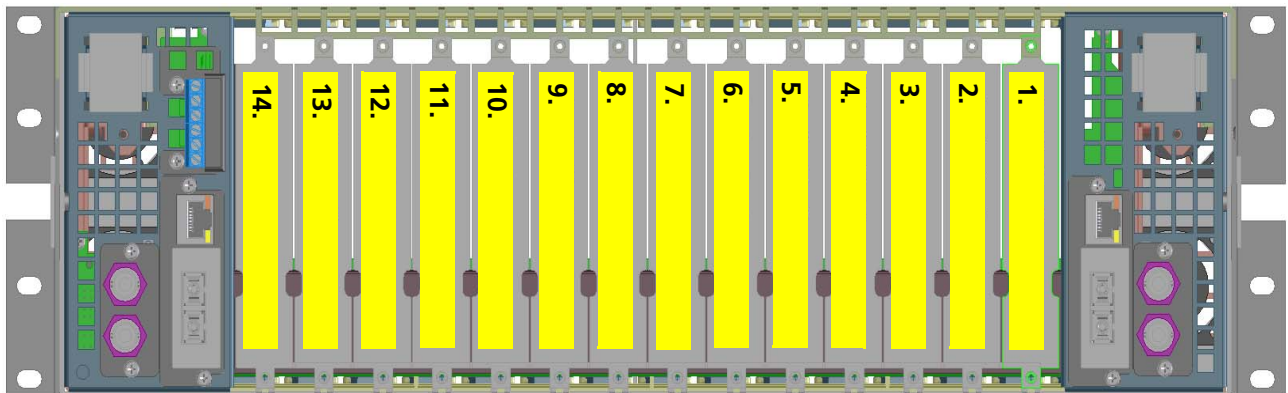

Figure 1-5. Writing Space for Identifying Back Modules



CAUTION:

Do not mix and match back and front modules. The front module must mate with a back module of the same product.

- 5 Open the front panel and then slide the correct front modules into the slots that match the back modules.
- 6 Push the module until it seats properly, ensuring the edge of the module is flush with the edge of the module guides, and the square extractor handle clicks into its slot.
- 7 Install the remaining back and front modules, make all of the necessary rear connections, and then close the front panel.



CAUTION:

To prevent overheating during frame operation, keep the front panel closed and all back module slots covered.

Removing Selenio Modules

Front Module To remove a front module from a Selenio frame, follow this procedure:

- 1 Open the front panel.
- 2 Grasp the extractor handle on the module, pulling down slightly.
- 3 Using the handle, slide the module out of its slot.

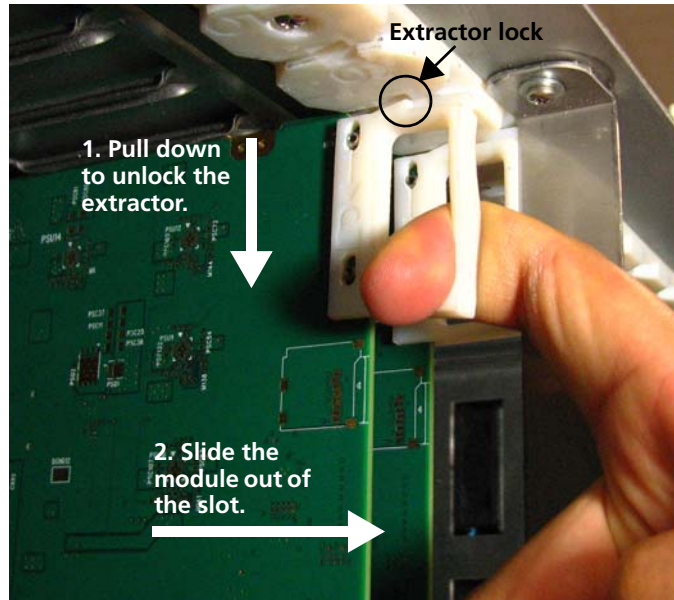

Figure 1-6 Removing a Front Module

- 4 Close the front panel to ensure proper frame ventilation.

Back Module To remove a back module from a Selenio frame, you must first remove the front module. Then unscrew the back module, and pull it straight out. Cover the opening with a blank back module to ensure proper frame ventilation.

Powering Up a Module

When an MDX1 is first powered up, the module takes several moments before it is operational. When the module appears in the Selenio UI, it is fully functional. The power consumption for an MDX1 module is approximately 25 W.

Upgrading Module Firmware

All module firmware upgrades are activated in the frame controller section of the Selenio user interface. Follow this path to find the appropriate parameters: **Configuration > Frame Controller > Configuration** tab > **Upgrade Firmware**.

See the Selenio frame manual for information on how to upgrade module firmware. In the unlikely event of an upgrade failure for the MDX1, see the Upgrade Failure Instructions of this manual.

Upgrade Failure Instructions

The MDX1 includes one user-configurable DIP switch array (**SW1**), located at the card edge next to the extractor. In normal operation, all four switches are in the **Off** position, set closest to the card edge. In the unlikely event of corrupted software, you may need to temporarily change the setting of **Switch 1** for the failsafe mode override. You would be alerted to this problem if a **System Recovery Upgrade Required** fault was triggered after an upgrade, and the module had finished rebooting.

If a **System Recovery Upgrade Required** fault is triggered, you should first try using the alternate firmware (see **Activating Alternate Firmware** in the frame manual) and then attempt the upgrade again. If this second attempt fails, follow these steps to activate the failsafe mode:

- 1 Remove the MDX1 module from the frame and then push **Switch 1** to the **On** position (furthest from the card edge).

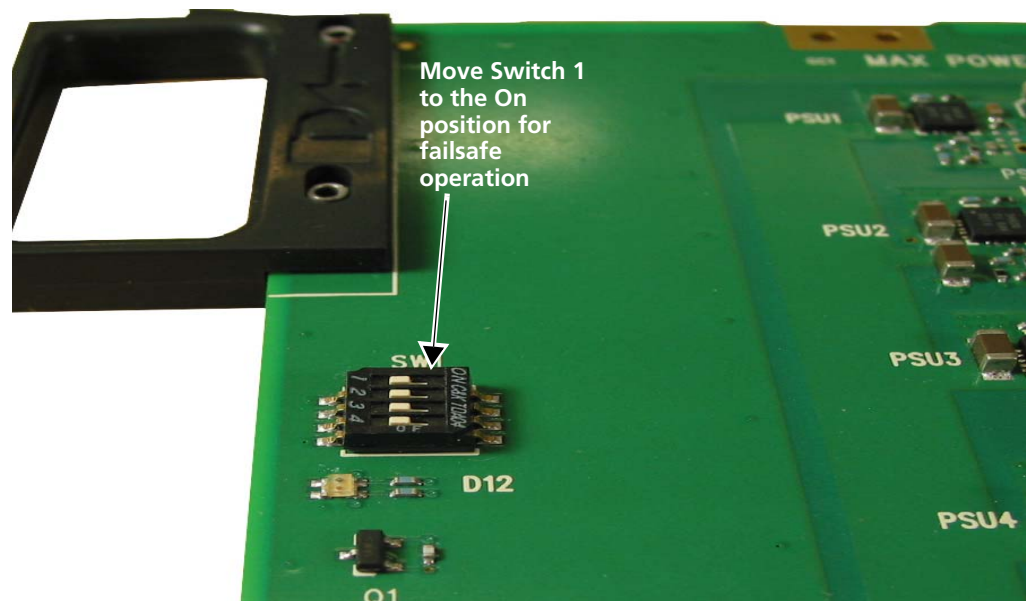

Figure 1-7 DIP Switch Setting for Failsafe Mode

- 2 Reinsert the module.
- 3 Install the new module software using the Selenio user interface.
- 4 Remove the module, and then return **Switch 1** to the **Off** position.
- 5 Reinsert the module.
The module is now running the new software.

Parameter Descriptions

The software controls described in this section are organized according to the block diagram shown in the **Configuration > Block View** of the Selenio user interface.

- **Module Name Block**
- **Function Map**
- **Demux PID Map**
- **IP LANs**
- **Multiplexers**
- **Demultiplexers**
- **Conditional Access System**
- **Conditional Access SCG 1-240**
- **Reference Clock**

Module Name Block

Name

Use this field to enter a unique name for the module, up to 31 characters in length.

Function Map

Type

The MDX module has eight function blocks each of which can be configured as either a multiplexer (**Type = Mux**) or demultiplexer (**Type = Dmx**).

When the type of the Nth function is set to **Mux**, the corresponding Nth **ASI/SMPTE 310M** external connector will be configured as an output.

When the type of the Nth function is set to **Dmx**, the corresponding Nth **ASI/SMPTE 310M** external connector will be available as an input.

If the type is set to **Off**, the corresponding function block and external connector are disabled.

The type can be set to **Copy** on even numbered functions blocks where the preceding function block type is set to **Mux**. In this case, the corresponding even numbered external connector will deliver a copy of the output of the preceding odd numbered **Mux** function block output.

Demux PID Map

The PID map makes it possible to split multiple program streams into a maximum of 240 programs. Each program is remapped according to the PID Table shown in the UI. The default setting for each PID is **-1**.

Default PIDs are based on offsets from a base PID of 48. They are:

- **PMT**: base + 0 (48)
- **Video**: base + 1 (49)
- **PCR**: base + 2 (50)
- **8 Audios**: base + 3 to base + 10 (51 - 58)
- **2 Data**: base + 11 and base + 12 (59, 60)
- **ECM**: base + 14 (62)

IP LANs

Primary and Secondary Data IP LANs

The Secondary Data IP LAN settings provided redundancy for the Primary settings. The backup functions provided by the Secondary Data IP LANs require the installation of a video IP submodule on the Selenio frame controller. When making settings in the IP LAN table, ensure that you click the **Apply** button to save your settings.

In a frame with a second controller (with the data Ethernet switch daughter card) the MDX module can receive and transmit on redundant primary and secondary IP data links.

On each physical link, IP interfaces can be configured for untagged network traffic (Vlan ID = 0) and tagged virtual LAN network traffic (Vlan ID 1 to 4094).

VLAN ID

This parameter sets the entry's VLAN identifier.

A value of 0 indicates that the interface is for untagged network traffic.
A value from 1 to 4094 indicates that the interface is for tagged virtual LAN traffic.

IP Address, IP Subnet Mask, and IP Gateway

These settings are required for the module's video gateway on the VLAN.

Time to Live

Use this field to set the time-to-live (TTL) value for IP packets carrying an MPEG transport stream on the selected VLAN. Each time a packet passes through a node, this number decreases. When the TTL value decreases to zero (without reaching the desired destination), the packet is discarded. The **Time to Live** range is **1** to **255** hops.

Primary and Secondary Data Eth MAC

This read-only parameter indicates the factory-set MAC ID.

Data Eth Protection

This parameter provides a switchover function, making it possible for you to choose **Primary**, **Secondary**, or **Automatic** switchover protection. When set to **Automatic**, a failure in the primary stream causes the module to switch to the secondary stream. The module will not return to the primary feed unless there is a failure on the secondary feed and the primary feed has been stable for 30 seconds.

Selected Data Eth Interface

This read-only parameter displays the status of the data ethernet protection.

Multiplexers

The following categories are available under Multiplexers:

- **General**
- **IP Destinations**
- **DVB**
- **DVBT**
- **Output TS Status**
- **Output IP Status**
- **Carousel Status**

The following options are common to all the multiplexer categories:

- **Input Channels**
- **DVBT Transmitter**
- **Output Program Status**

Input Channels

Delete Channel

Deletes this channel's association with its current multiplexer function.

Function

Use this parameter to set the payload type and processing for this virtual channel.

- **Program** specifies the channel will carry a program to be multiplexed into the transport stream of the referenced port.
- Using the **PID** option, a single PID's packets are inserted into the transport stream. The packets will be remapped to the channel's PID parameter and inserted into the selected port's multiplex.

The following principles apply to the PID option:

- When a PID is configured for individual extraction, its packets must not be routed through any other VC on the interface.
- No other VC should reference the PID for extraction from the multiplex, either explicitly or implicitly; otherwise a **Transmit Channel Configuration Error** fault is triggered.

This function supports "unusual" applications and might require application engineering support to configure correctly. The VC carrying this single PID may be connected like a normal multiplexer VC. Some destinations, such as decoders, are unlikely to process it successfully, but the system does not prevent the connections. The most useful destination is likely to be a multiplexer VC, whose function is set to insert a specific PID into a multiplex.

When a value of **0** is set in the **Program Number** field, the PID is not added to the PAT or any PMT. A non-zero value forces the system to search for another channel on the same interface that carries a matching program (its function should be {program, transrate}, and the program number should match this channel's value). This channel's PID is then added as a program element to the identified program, including the associated PMT entry. The channel's configured stream type is used in the element's PMT entry. If no matching program channel exists, the channel asserts an alarm configuration error fault.

The VC's interface is an external receiver with passthrough enabled. Some function values consume limited internal resources. If any constraints are violated, the module will declare a **Configuration Error** fault.

Source Type

The following sources are available:

- CXN (internal IP network)
- Ext IP-CBR
- Ext-IP-VBR

Program Number

Specifies the program number associated with this channel. When multiplexing several programs to form a multi-program transport stream, this specifies the program number that will be associated in the PAT with the data from this channel. The data from multiple channels with the same program number will be merged. If the program number is zero, the data from this channel will be added without a PAT entry. Use this field to set the program number associated with this demux VC entry.

Policing Rate

The value in the **Policing Rate** field sets the policing behavior for this virtual channel. VC's with **PID** or **Program** will discard packets that cause the stream to exceed this rate. When **0** is entered in the field, data is allowed up to the maximum rate permitted by the interface. With a setting of **1** to **214**, data is policed at the rate specified.

Priority

This setting specifies the relative priority for this channel. Options are **Normal** and **Low**.

Inserted PID

When the channel's **Function** is set to PID, this parameter specifies which packets to extract from the interface's transport stream. Other VC functions ignore this setting.

- The default value of **-1** cannot occur in a transport stream. If the channel is configured for single-PID processing, this gives a "safe" default value that cannot match any packets (and thus avoids duplicating a PID in an active program). Additionally, channels configured for other functions use **-1** to indicate the absence of specific PID extraction.
- With values of **1** to **8190**, packets from the specified input PID are remapped to PID **42** before transferring them through the VC. When processing a full program from a demultiplexer, the system remaps the program number to **1** and all the PIDs starting at **32**. For a full program, PID **59** corresponds to the first assigned data PID within the program. Because a single-PID channel normally would carry data, the designated output PID is remapped to **59**. For symmetry, a **Multiplexer VC** that inserts a single PID also uses packets from PID **59**.



CAUTION: Do not insert a value of "0". This value causes the TMX module to insert packets on the stream's program allocation table (PAT) and will interfere with program processing.

Stream Type and Descriptors

The value in the **Stream Type** field (**0** to **255**) specifies the stream type for this channel's program element. The Descriptor text is a string of colon (:) separated two digit hexadecimal characters used to represent MPEG descriptors that are to be inserted directly into the PMT.

DVBT Transmitter

Identifier

Use this field to set the address identifying this transmitter. The value **0x0000** “broadcasts” to all transmitters in the network.

Time Offset and Time Offset Enable

Use the **Time Offset** field to specify the offset of local time from UTC time before the daylight saving time transition. The range is **-12:00** to **+12:00** (hours:minutes). Numbers above **0** do not require a **+** sign. This parameter is used with the **Time Offset Enable** parameter.

Frequency Offset and Frequency Offset Enable

The value in the **Frequency Offset** field sets the amount of offset of the centre frequency of the emitted DVB-T signal relative, to the centre frequency of the RF channel. This is expressed in kHz.

Tx Power and Tx Power Enable

Use these parameter to set and enable the transmitter’s power effective radiated power in decibels.

General

New Channel and New Channel Assigned

The **New Channel** parameter allocates a new channel for this multiplexer function; **New Channel Assigned** indicates the index of the most recent channel that was allocated to this multiplexer.

Standard

The SEL-MDX1 multiplexes the following output standards:

- ASI-188-ACBR, CBR, and VBR
- ASI-204-ACBR, CBR, and VBR
- ASI-DVB-T and DVB-T-SFN
- SMPTE 310M

The **ASI-188-CBR** and **ASI-204-CBR**-standards use Asynchronous Serial Interface (ASI) with a constant bit rate. The downstream receiver must be explicitly configured to use either 188-byte, or 204-byte packets, as per this setting. The module reads packets out of its buffer at a constant rate and inserts null transport stream packets to bring the **Output Rate** of the multiplexer up to the required value.

ASI-188-VBR and **ASI-204-VBR** use an Asynchronous Serial Interface (ASI) with a variable bit rate. The downstream receiver must be explicitly configured to use either 188-byte, or 204-byte packets, as per this setting. The module reads packets out of its buffer at the highest variable rate possible (therefore variable) without exceeding the configured **Output Rate**. No null packets are inserted, so the resulting stream may not consume the entire configured rate.

SMPTE-310M carries MPH (mobile/pedestrian/handheld) information. The module reads packets out of its buffer at a constant rate and inserts null transport stream packets or opportunistic data to bring the output rate of the multiplex up to the SMPTE-310M rate (19.39265846 Mbps with 188-byte packets).

Passthrough

This parameter specifies whether to bypass the port's multiplexer.

When **Enable** is selected, the interface transmits one multi-program transport stream as input and makes that stream available on one VC, which may then serve as a cross-connection source. The **Disable** option multiplexes the input stream into one or more single-program transport streams. Each program may be directed to its own VC and each such VC may serve as a cross connection source.

If more than one VC is configured to operate on this interface, only the first VC is used, and a configuration alarm is raised. To clear the alarm, delete all but one VC and then **Enable** this control.

Output Rate

This parameter sets the output bit rate of the transport stream. The range is **0** to **214** Mb/s, but this is limited by the standard selected.

- **0** to **213.72** is the range of available when the **Standard** parameter is set to either **ASI-188-CBR** or **ASI-188-VBR**. (When using this **Standard** setting, every 8-bit byte occupies 10 bits on the physical medium. Additionally, packets are separated by 2 padding bytes.

Using this format, the carrier rate (or raw bandwidth) for a given transport stream rate is the following:

$$\text{carrier_rate} = \text{ts_rate} * (10/8) * (190/188)$$
$$213.7263158 = 270 * (8/10) * (188/190)$$

- **0** to **197.12** is the range of rates when the **Standard** is set to either **ASI-204-CBR** or **ASI-204-VBR**. Every 8-bit byte occupies 10 bits on the physical medium. Additionally, packets are separated by 2 padding bytes. Finally, the rate is computed for 188-byte packets, even though 204 bytes of data are present.

Using this format, the carrier rate (or raw bandwidth) for a given transport stream rate is the following:

$$\text{carrier_rate} = \text{ts_rate} * (10/8) * (206/204) * (204/188)$$
$$197.1262136 = 270 * (8/10) * (204/206) * (188/204)$$

- **0** to **19.39** is the range of rates when the **Standard** is set to SMPTE-310M.

SI Mode

Use this field to specify the system information table paradigm.

- **MPEG** processes and preserves generic MPEG control tables, but discards MPEG application-specific SDTs.
- **DVB** processes and preserves Digital Video Broadcasting (DVB) control tables. This setting forwards the SDT on PID **17** through the demultiplexer.
- **None** discards all incoming SI/PSI tables. Use this SI mode when a streamer or data carousel is providing the PAT and PMT.

Transport Stream ID

This parameter sets the transport stream ID transmitted in the system information tables.

Base PID

Base PID applies to Program 1 on this interface. When the **PID Map** operates in **Auto**, this base value helps compute the first PID for a channel's program. Other PID mapping conventions ignore this base PID value.

Carousel Rate

This parameter sets the data carousel bitrate for the interface (from **0** to **16,000,000** bps). If the interface's carousel has streaming enabled, this bitrate governs the maximum transport stream bandwidth that will be used by carousel data. The quantity, and rate of other carousels on this interface may limit the maximum rate per carousel.

Carousel Stream

Data carousel streaming is enabled or disabled by this setting. **Enable** turns on carousel handling. If a valid carousel file is present, and its activation time has arrived, the file's data will be multiplexed into the interface's transport stream. **Disable** turns off carousel streaming. Any existing carousel files are ignored, and the interface does not check for new carousel files, nor is carousel data multiplexed into the transport stream.

PID Map

Use this control to specify whether PIDs in programs on this interface should be mapped automatically or manually.

In the **Auto** setting, the module uses its own **Base PID** and the VC's program number to determine a **Base PID** value for the program. It then assigns a group of 16 PIDs to the program as described in [Table 1-4](#). The **Base PID** is assigned to program number **1**.

In **Manual** mode, each VC specifies its own PID values, using the configuration values in the VC's program group. MPEG defines a packet identifier as a 13-bit number, reserving 0 through 15 and 8191 (0x1FFF). The ATSC standard further reserves PIDs below 48. Moreover, the ATSC program guide (PSIP) tables conventionally use PIDs at 7680 (0x1E00) and above. The automatically assigned values avoid these ranges, and uses values from 32 to 7167 (0x1BFF).

Note: In **Manual** mode, all PIDs for the interface must be unique. If a VC tries to use a PID that has already been assigned on the same interface, the VC will declare a **Transmit Channel Configuration Error** fault.

Table 1-4 Automatic PID Mapping Formula Example Based on ATSC Recommendations

PID Type	Formula	Example	PID Number
Program Number	Interface Base PID + 16 * (program number - 1) = 96 *	4	–
PMT (Base) PID	Base PID + 0*	96 + 0	96
Video PID	Base PID + 1	96 + 1	97
PCR PID	Base PID + 2	96 + 2	98
Audio 1 PID	Base PID + 3	96 + 3	99
Audio 2 PID	Base PID + 4	1 + each subsequent Audio PID.	100
Data 1 PID	Base PID + 11	96 + 11	107
Data 2 PID	Base PID + 12	1 + each subsequent Data PID.	108
ECM 1 PID	Base PID + 14	96 + 14	110
ECM 2PID	Base PID + 15	1 + each subsequent ECM PID.	111

* This example assumes base PID is 48.

IP Destinations

The following categories are available under IP Destinations:

- Primary VLAN ID
- Primary IP Address
- Primary IP Port
- Secondary VLAN ID
- Secondary IP Address
- Secondary IP Port
- FEC
- FEC Order
- FEC Period
- FEC Row
- TS Packets per IP
- Type of Service

DVB

Network Id

This 16-bit value identifies the network delivery system when the system information mode is set for DVB. Other SI modes ignore this value. See *DVB A038* and *ETSI ETR-162* for details.

EMM Base PID

This setting (from -1, to 32–8190) is used with **Conditional Access**. The default value of **-1** assigns the EMM Base PID to **8144**. The actual range of possible **EMM Base PID** values is **32-8191**.

DVBT

The following categories are available under DVBT:

- Maximum Delay
- Modulation
- Hierarchy
- HP Code Rate
- Guard Interval
- Transmission Mode
- Bandwidth
- Priority

Output TS Status

The following categories are available under Output TS Status:

- Standard
- Output Rate
- Packets
- TS ID
- PAT Version
- Err Sec
- Overflows

Output IP Status

The following categories are available under Output IP Status:

- Primary IP Rate
- Primary IP Packets
- Primary IP Fault
- Secondary IP Rate
- Secondary IP Packets
- Secondary IP Fault

Carousel Status

The following categories are available under Carousel Status:

- Status
- Packets
- Current Ident

- Current Start
- Current Late Pkts
- Next Ident
- Next Start

Demultiplexers

The following categories are available under Demultiplexers:

- **General**
- **IP Source**
- **Input TS Status**
- **Input IP Status**

The following options are common to all the demultiplexer categories:

- **Output Channels**
- **Input Program Status**

General

New Channel and New Channel Assigned

These parameters allocate a new channel for this demultiplexer function, and indicate the index of the most recent channel that was allocated to this demultiplexer.

Source Type

This control sets the source type for this demultiplexer input. Options are:

- CXN (internal frame IP network)
- Ext-Mod (default; back module ASI/SMPTE 310M input)
- Ext-IP-CBR
- Ext-IP-VBR

Passthrough

This parameter specifies whether to bypass the port's demultiplexer. When **Enable** is selected, the interface transmits one multi-program transport stream as input and makes that stream available on one VC, which may then serve as a cross-connection source. The **Disable** option multiplexes the input stream into one or more single-program transport streams. Each program may be directed to its own VC and each such VC may serve as a cross connection source.

If more than one VC is configured to operate on this interface, only the first VC is used, and a configuration alarm is raised. To clear the alarm, delete all but one VC and then **Enable** this control.

SI Mode

Use this field to specify the system information table paradigm.

- **MPEG** processes and preserves generic MPEG control tables, but discards MPEG application-specific SDTs.
- **DVB** processes and preserves Digital Video Broadcasting (DVB) control tables. This setting forwards the SDT on PID **17** through the demultiplexer.

Standard

Use this parameter to set the input source to **Auto** or **ASI**.

IP Source

The following options are available under IP Source:

- Primary VLAN ID
- Primary IP Group
- Primary IP Port
- Primary Mcast Src 1
- Primary Mcast Src 2
- Secondary VLAN ID
- Secondary IP Group
- Secondary IP Port
- Secondary Mcast Src 1
- Secondary Mcast Src 2

Input TS Status

The following options are available under Input TS Status:

- Standard
- SI Presence
- Input Rate
- Packets
- TS ID
- PAT Version
- Errored Seconds
- Line Errors
- Loss of Frame
- Loss of Signal

Input IP Status

The following options are available under Input IP Status:

- Corrected Packets
- Uncorrectable Packets
- Delay Variation
- IP Encapsulation
- TS Per IP
- Column FEC
- Row FEC
- FEC Order
- FEC Period
- Primary IP Packets
- Secondary IP Packets

Output Channels

Delete Channel

This parameter deletes the channel's association with its current demultiplexer function.

Function

The **Function** parameter sets the payload type and processing for this virtual channel to either **Program**, **PID**, or **Off**.

Destination Type

The selected channel is transmitted to cross connected destinations within the frame (**CXN**) or to an external IP destination (**Ext-IP**). If the destination is external, the channel can be specified to be variable bit rate (**VBR**) or constant bit rate (**CBR**). The default is **CXN**.

Program Number

When demultiplexing MPTS input, the program number selects a particular program from the transport stream and directs that program to this channel. All output channels for an interface must specify a unique program number.

CBR \ Policing Rate

This parameter sets the output policing rate for data transmitted on the channel. Data is allowed up to the maximum rate set in this field and excess packets are discarded. Setting the value to **0** disables policing. If CBR processing is selected on this channel, the output bit stream is padded up to this rate.

Policing can occur at a rate between **1** and **214** Mb/s. Virtual channels with the **PID** or **Program** function will discard packets that cause the stream to exceed this rate.

PID

This parameter sets the packet identifier (PID) value associated with this VC. When **PID** is selected in the **Function** parameter, the packet identifier specifies which packets to extract from the interface's transport stream. Other VC functions ignore this setting.

The default setting of **-1** cannot occur in a transport stream. If the channel is configured for single-PID processing, this gives a "safe" default value that cannot match any packets (and thus avoids duplicating a PID in an active program). Additionally, channels configured for other functions use **-1** to indicate the absence of specific PID extraction.

Values from **1** to **8190** are remapped to PID **59** before they are transferred through the VC. When processing a full program from a *multiplex*, the system remaps the program number to **1** and all the PIDs starting at **32**. For a full program, PID **59** corresponds to the first assigned data PID within the program. Because a single-PID channel normally would carry data, the designated input PID is re-mapped to **59**. For symmetry, a multiplexer VC inserts a single PID also uses packets from PID **59**.



CAUTION:

Do not use "0" as a value. This value extracts the stream's program allocation table (PAT), disabling program processing.

FEC

Use this parameter to select the mode of forward error correction (FEC) for the selected IP virtual channel. This value applies to IP channels transmitting MPEG transport stream data, generating RTP parity packets according to *RFC 2733*. This value should be set to **None-UDP** or **None-RTP** for MPEG receivers and VCs configured for other channel functions.

To enhance error recovery, parity packets can be computed on a repeating, conceptual grid overlaid on the data packets. This grid has period columns (L) and order rows (D), as described by *Pro-MPEG Code of Practice #3, January 2003*.

With forward error correction enabled, the correction packets are sent to and received from a different port from the transport stream packets. The channel's transmit rate includes only the transport stream data; error correction overhead (and IP overhead) must be separately computed to determine the entire bandwidth for the video-on-IP stream.

In the MPEG data stream, each IP packet carries up to 7 transport stream packets (as set in the **TS Packets Per IP** parameter), possibly wrapped in additional protocols. Each FEC parity packet carries error correction data for those transport stream packets. That FEC payload rides in an ethernet frame with a 14-byte header, carrying an IP packet with a 20-byte IP header, an 8-byte UDP header, a 12-byte RTP header, and a 16-byte FEC header.

None-UDP and **None-RTP** disable forward error correction for this virtual channel. The **Low** setting is equivalent to generating 1 parity packet for every 16 data packets. **Medium** is equivalent to generating 5 parity packets for every 40 data packets, and **High** is equivalent to generating 20 parity packets for every 80 data packets.

FEC Order, Period, and Row

The **FEC Order** for this virtual channel corresponds to the *depth* of the conceptual grid used for forward error correction. Values are from **4** to **20**. The **FEC Period** of 1 to 20 corresponds to the *width* of the conceptual grid used for forward error correction. **Row FEC** can also be enabled, to be used in addition to column FEC.

TS Packets Per IP

The value in this field (**1** to **7**) sets the number of transport stream packets per IP packet.

Demultiplexer PID Map

PIDs: ECM, PCR, PMT, Video, Audio, and Data

The initial packet identifiers for ECM, PMT, Video, etc., are only applicable when the **PID Map** parameter is set to **Manual**. If the program has multiple ECM streams, subsequent PIDs are assigned consecutively.

-1 is the default value, which cannot occur in an MPEG stream. Virtual channels configured for automatic PID assignment can use **-1** to indicate the absence of specific PID assignment. The values of **0** to **15** are reserved to carry the program association table (PAT) and other standard tables. If the VC is configured for manual PID assignment and this parameter is set to a value between **-1** and **15** while the VC is active, the module triggers a **Configuration Error** fault.

16 to **8090** is the range of possible PID values; a value of **8191** indicates that this VC carries only null packets. This parameter's upper limit, **8190**, excludes the null PID.

Conditional Access System

Vendor and CA Systems ID

Use the **Vendor** parameter to select the manufacturer of your external conditional access system, and the CA System ID for the code assigned by the vendor.

- Generic
- Irdeto
- Conax
- Irdeto

ECMG

Sub CAS ID

Use this field to set the sub CA system ID of the Conditional Access System. Must be unique for each ECMG.

Multiplexer

This parameter sets the index of the multiplexer function associated with the Simulcrypt conditional access ECM generator. A value of **0** indicates this **ECM** generator is inactive.

EMMG

Multiplexer

Specifies the index of the multiplexer function associated with this EMM Generator. A value of **0** indicates this EMMG is inactive.

Protocol

Connections are always **TCP** but data transfer can be **TCP** or **UDP**. This setting must be coordinated with the same setting on the Conditional Access System itself.

Max EMM Data Rate

This control sets the maximum bandwidth to be consumed by EMMs on the transport. This bandwidth must be taken into account when allocating the rate on programs and other data on the interface.

CAT Descriptor

MPEG descriptors to be inserted directly into the conditional access table (CAT). They are formatted as colon (:) separated two digit hexadecimal characters. The user is responsible for making sure the descriptor is valid and well formed.

Access Criteria

Value

When the vendor field is set to **Generic**, this provides a method to set the access criteria specific to a conditional access system.

Conditional Access SCG 1-240

Multiplexer

Use this field to set the index of the multiplexer function associated with this scrambling control group. A value of **0** indicates this SCG is inactive.

Crypto Period

This value sets the *suggested* crypto period for this scrambling control group. The actual crypto period is negotiated at connection to an ECMG.

ECM

System Index

This value is the index of the CAS entry associated with the ECM. Use this value to identify the appropriate ECMG to attach ECM.

Service ID

This assigned service ID is typically is the program number in the transport multiplex.

AC Index

This value sets the access criteria index for this ECM. A value of **0** (the default setting) specifies that the access criteria should be generated automatically.

ECM PID

The value in this field sets the PID for this SCG ECM. The value must be unique across all PIDs in the multiplex.

Encryption Mode

This parameter selects BISS or Simulcrypt encryption. With encryption operating, a program can be scrambled and passed over an insecure medium to an authorized decoder, which can unscramble the stream. If **None** is selected, the encryption process is disabled, so the multiplexer provides unscrambled output.

When **BISS** is selected, encryption is enabled. This option directs the multiplexer to use its **BISS SW** (session word) to scramble the output MPEG stream. A decoder will need the session word in order to decrypt the stream. For details, see *EBU Technical Specification Tech 3292 (rev. 2, August 2002), BISS-E, Basic Interoperable Scrambling System with Encrypted Keys*.

SCG Index

This parameter sets the index of the Simulcrypt Scrambling Control Group associated with the channel.

BISS SW

Use this parameter to set the BISS session word for this program. The multiplexer channel allows its session word to be written and read (unlike the decoder, which protects its session word from being read). A session word behaves like a “normal” configuration value and may be stored internally as a profile. Loading a stored preset or configuration file can alter session words for the system's multiplexers. Additionally, a session word follows the active service during module failover and failback.

When **None** is selected, all scrambling is disabled. This value may be the empty string.

A session word is a 12-character, hexadecimal string, such as **0a3b5c7d9e1f** (upper-case and lower-case letters allowed). This hexadecimal string does not require an **0x** prefix.

Reference Clock

Reference Clock

Use this parameter to select the interface line clock source. To ensure proper communication, the sender and receiver must synchronize their data clocks.

- The **Int** option uses the module's own internal clock.
- The **Ref** option uses the frame's controller module as a source.
- **GPS1** uses the input signal from the 1 PPS connector on the back module.
- **GPS10** uses the input from the 10 MHz connector on the back module.

Specifications

ASI Input and Output Specifications

Table 1-5 ASI Input

Item	Specification
Number of inputs	up to 8
Standard	EN 50083-9
Connector	HD-BNC
Data rate	0-210 Mb/s
Min. sensitivity	200 mV
Max. input voltage	88 mV (pk-to-pk)
Min. discrete connector return loss	-15 dB (0.3 MHz to 1 GHz)

Table 1-6 ASI Output

Item	Specification
Number of outputs	up to 8
Standard	EN 50083-9
Connector	HD-BNC
Data rate	0 to 210 Mb/s
Output voltage	800 mV 10% (pk-to-pk)
Clock rate	270 MHz \pm 100 ppm
Deterministic jitter	10% (pk-to-pk)
Random jitter	8% (pk-to-pk)
Max. rise and fall time	1.2 ns (20-80%)

SMPTE 310M Input and Output Specifications

Table 1-7 SMPTE 310M Input

Item	Specification
Connector	HD-BNC
Load	5 Ω resistive
Peak-to-peak voltage	80 mV-200 mV pk-to-pk
Rate	9.392658 MHz \pm 100 ppm
Format	i-phase-mark coding
Applicable standards	SMPTE 310M

Table 1-8 SMPTE 310M Output

Item	Specification
Connector	HD-BNC
Peak-to-peak voltage	00 mV \pm 10%
Rate	9.392658 MHz +/- 2.8ppm
Format	i-phase-mark coding
Applicable standards	SMPTE 310M

Reference Clock

Table 1-9 10 MHz Reference

Item	Specification
Connector	HD-BNC
Waveform	Sinusoidal 7 dBm nominal
Termination	50 Ω

Table 1-10 1 PPS Reference

Item	Specification
Connector	HD-BNC
Waveform	10- μ S TTL Pulse
Termination	>10K Ω

Index

A

Access criteria 26, 27

B

Back module diagrams 4
Base PID 18
BISS 27, 28
Block diagrams 6

C

CAT descriptors 26
Conditional access SCG 1-240 27–28
Conditional access system 25–26
Crypto period 27

D

Data Eth Protection 12
Data IP LANs 11
Delete Channel parameter 23
Demultiplexer PID map 11, 25
Demultiplexers 21–25
Destination type 23
DVB network ID 19
DVBT 20
DVD transmitter 16

E

ECM 27–28
ECM PID 27
ECMG parameters 26
EMI gaskets 7
EMM Base PID 20
EMMG parameters 26
Encryption mode 27
Eth MAC 12
Extractor handle 8

F

Features of the module 1–3

Forward error correction (FEC) 24–25
Frequency offset 16
Function map 10–11
Function parameter 14

I

Input IP status 23
Input TS status 22
Inserted PID 15
Installing modules 7
IP
 address, subnet mask, and gateway 12
 destinations 19–21
 LANs 11–12
 source 22

M

MAC ID 12
Manual information v
Maximum EMM data rate 26
Module
 descriptions and types 5
 installation 7
 name lock 10
 removal 8
Multiplexers 13–21

N

Network ID, DVB 19
New Channel parameter 16, 21

O

Output
 bit rate 17
 channels 23–25
 standards 16–17

P

Packet identifier (PID) 24
Passthrough 17, 21

PID map 18–19, 25
Policing rate 15, 23
Power consumption specification 9
Powering up the module 9
Priority 15
Product servicing vi
Program Number parameter 14, 15, 23

R

Reference clock 28
Removing modules 8
Returning a product vi
Revision history of the manual v
RoHS compliance vii

S

Safety
 precautions viii
 standards and compliances vii
 terms and symbols viii
Service ID 27
Shipping information vi
SI Mode parameter 17, 22
Signal flow diagrams 6
Simulcrypt 27, 28
Softkey options 5

Source type 14, 21
Specifications 29–30
Standards
 output 16–17
 RoHS compliance vii
 WEEE compliance vii
Stream Type 15

T

Time offset 16
Time to live 12
Transmit Channel Configuration Error 14, 18
Transmitter power 16
Transport stream ID 18

U

Unpacking information vi

V

VLAN ID 11

W

WEEE compliance vii

For more information, please visit www.broadcast.harris.com.

Harris is a registered trademark of Harris Corporation. Trademarks and tradenames are the property of their respective companies.



Broadcast Communications Division
25 Dyas Road | North York, ON CANADA M3B 1V7 | Tel: (416) 445 9640
www.broadcast.harris.com

©2011 Harris Corporation